

尺寸圖

DRAWING & DEMENSION

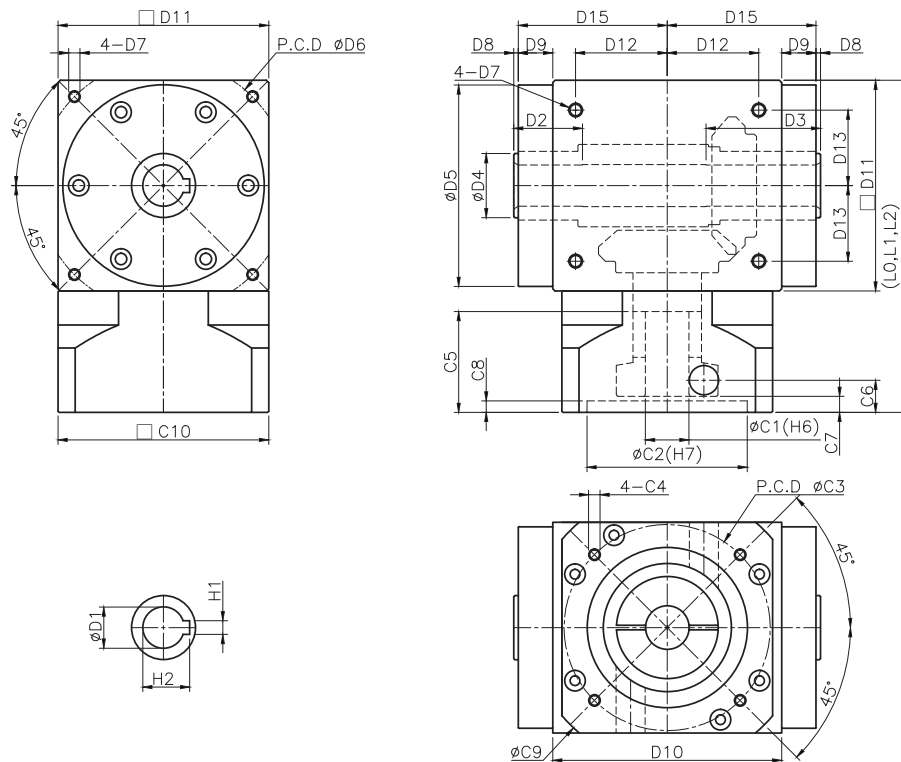

(單位：mm)
(Unit：mm)

尺寸 Size	MFT60-S0	MFT90-S0	MFT 120-S0
ØD1	13	18	22
D2	30	30	35
D3	30	50	55
ØD4	20	28	35
ØD5	62	88	108
ØD6	76	110	145
D7	M4x0.7P	M6x1.0P	M8x1.25P
D8	2	2	2
D9	13	15	15
D10	70	100	126
D11	62	92	120
D12	25	40	50
D13	25	33	42
D15	48	65	78
H1	5	6	6
H2	15.3	20.8	24.8
L0 零段 (stage 0)	101.5	141	198
L1 一段 (stage 1)	130	185.5	254
L2 二段 (stage 2)	146	213	287.2
ØC1	6-14	14-19	16-24
ØC2	50	70	110
ØC3	70	90	145
C4	M5x0.8P(MAX)	M6x1.0P(MAX)	M8x1.25P(MAX)
C5	33	39	65
C6	13	15	28.5
C7	7	7	20
C8	4	5	7
ØC9	80	120	161
C10	60	92	120

* 註：C1-C6 為標準品最大尺寸，為公制標準馬達連接板尺寸，尺寸依搭配的馬達而改變。如超出尺寸屬特殊規格請與我司聯絡。

* Note：C1-C6 are metric standard specific dimensions of motor. Please contact us at vgm@vgmgear.com for other specification or customize product..

尺寸圖 DRAWING & DEMENSION

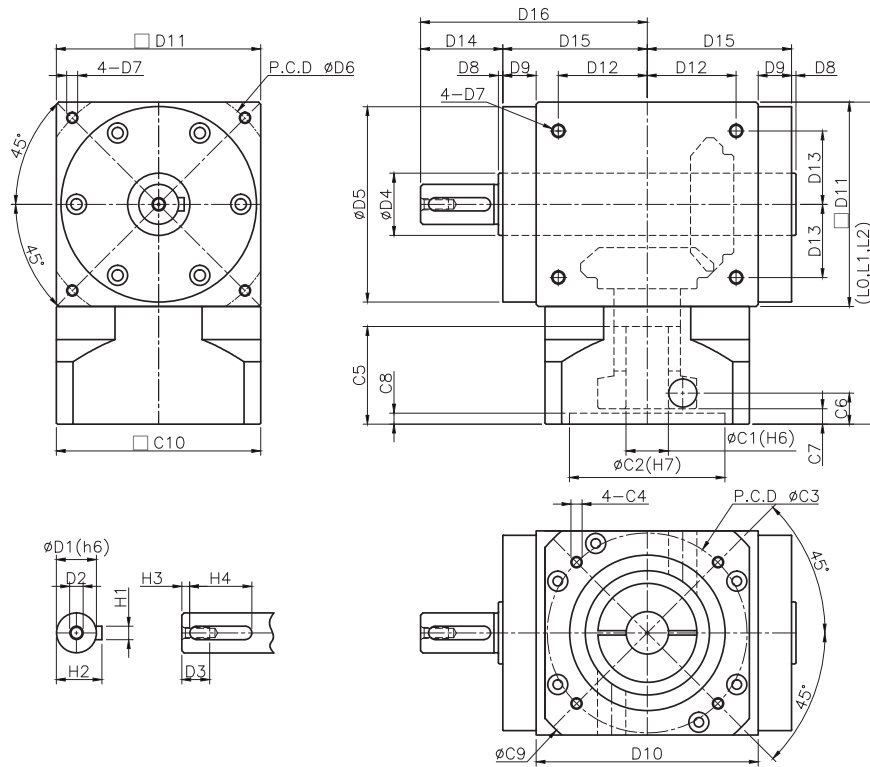

(單位：mm)
(Unit：mm)

尺寸 Size	MFT60 -S1	MFT90-S1	MFT120-S1
ØD1	13	18	22
D2	M4x0.7P	M5x0.8P	M8x1.25P
D3	12	14.5	22
ØD4	20	28	35
ØD5	62	88	108
ØD6	76	110	145
D7	M4x0.7P	M6x1.0P	M8x1.25P
D8	2	2	2
D9	13	15	15
D10	70	100	126
D11	62	92	120
D12	25	40	50
D13	25	33	42
D14	22	37	42
D15	48	65	78
D16	70	102	120
H1	5	6	6
H2	15	20.5	24.5
H3	2	3.5	5
H4	16	25	25
L0 零段 (stage 0)	101.5	141	198
L1 一段 (stage 1)	130	185.5	254
L2 二段 (stage 2)	146	213	287.2
ØC1	6-14	14-19	16-24
ØC2	50	70	110
ØC3	70	90	145
C4	M5x0.8P(MAX)	M6x1.0P(MAX)	M8x1.25P(MAX)
C5	33	39	65
C6	13	15	28.5
C7	7	7	20
C8	4	5	7
ØC9	80	120	161
C10	60	92	120

* 註：C1-C6 為標準品最大尺寸，為公制標準馬達連接板尺寸，尺寸依搭配的馬達而改變。如超出尺寸屬特殊規格請與我司聯絡。

* Note : C1-C6 are metric standard specific dimensions of motor. Please contact us at vgm@vgmgear.com for other specification or customize product.

尺寸圖

DRAWING & DEMENSION

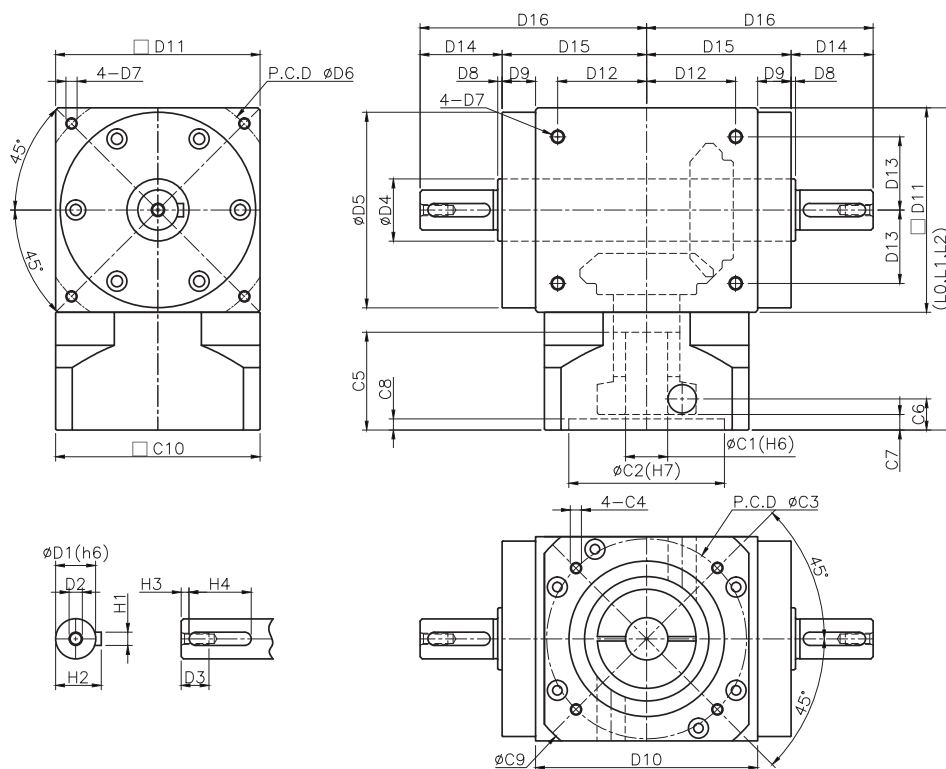

(單位：mm)
(Unit：mm)

尺寸 Size	MFT60-S2	MFT90-S2	MFT120-S2
ØD1	13	18	22
D2	M4x0.7P	M5x0.8P	M8x1.25P
D3	12	14.5	22
ØD4	20	28	35
ØD5	62	88	108
ØD6	76	110	145
D7	M4x0.7P	M6x1.0P	M8x1.25P
D8	2	2	2
D9	13	15	15
D10	70	100	126
D11	62	92	120
D12	25	40	50
D13	25	33	42
D14	22	37	42
D15	48	65	78
D16	70	102	120
H1	5	6	6
H2	15	20.5	24.5
H3	2	3.5	5
H4	16	25	25
L0 零段 (stage 0)	101.5	141	198
L1 一段 (stage 1)	130	185.5	254
L2 二段 (stage 2)	146	213	287.2
ØC1	6-14	14-19	16-24
ØC2	50	70	110
ØC3	70	90	145
C4	M5x0.8P(MAX)	M6x1.0P(MAX)	M8x1.25P(MAX)
C5	33	39	65
C6	13	15	28.5
C7	7	7	20
C8	4	5	7
ØC9	80	120	161
C10	60	92	120

* 註：C1-C6 為標準品最大尺寸，為公制標準馬達連接板尺寸，尺寸依搭配的馬達而改變。如超出尺寸屬特殊規格請與我司聯絡。

* Note: C1-C6 are metric standard specific dimensions of motor. Please contact us at vgm@vgmgear.com for other specification or customize product.